

STATEMENT

Indiana Mine Rescue Contest

June 7, 2012

Hello, thank you coming to help. My name is _____, the mine manager in charge of the fresh air base. This is the information you will need:
(Give statement to team.)

You and your team are located at the fresh air base on this three entry developing section, known as the 3rd East off the Main North. This section is developing to the boundary and will pull pillars on the way out.

Last night on midnight shift an idle crew went in to do some maintenance activities and work on a fall in Number 1 if they had time. The only other crew in the mine was at the opposite end of the mine. We are not sure what happened but we lost contact and have been unable to reach the four workers. The last known location of them according to our tracking system was on this unit. Everyone else in the mine has been accounted for.

We attempted to travel into the section but became worried with some of the gas readings we were getting and have set up the fresh air base here.

The mine is ventilated by an exhausting system and the air is flowing from the right to the left as indicated. This fan cannot be shut off or reversed.

All underground power has been disconnected and guarded. There is a backup mine rescue team on site. All state and federal agencies have been notified and are on site also.

The map you will receive is up to date. There are no old works nearby and there are no shafts or boreholes in this section of the mine.

PROBLEM

1. You are to account for all missing persons.
2. Bring all survivors to the fresh air base.
3. Explore the mine in its entirety if you can do so safely.

Patient Statement

(Barricade)

Help. Help.
I'm okay. The air in here is fine. Come and
get me.

Patient Statement

(Refuge Alternative)

Help. Help.

I'm fine. Hurry up and get me out of this tin
can.

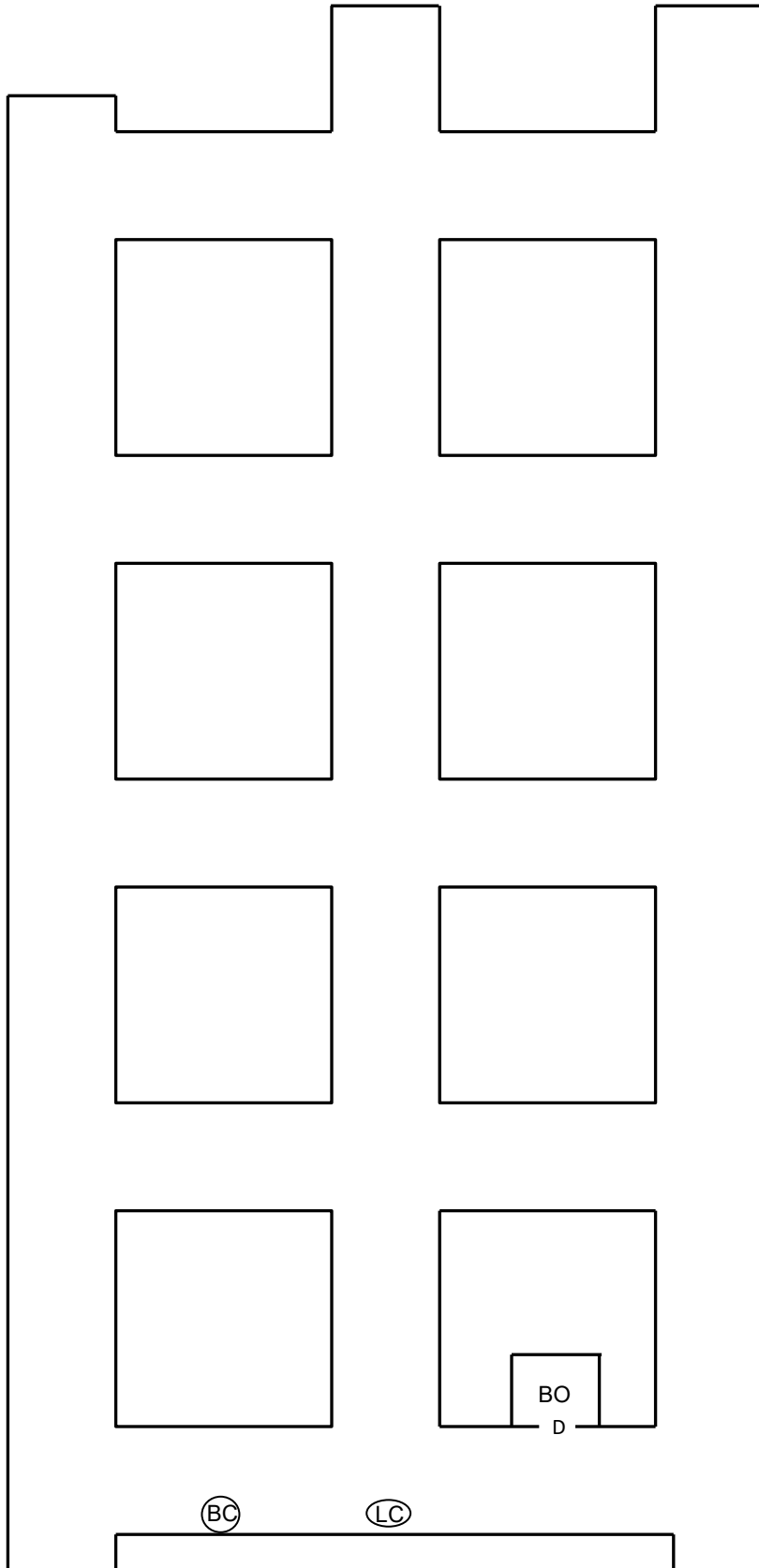

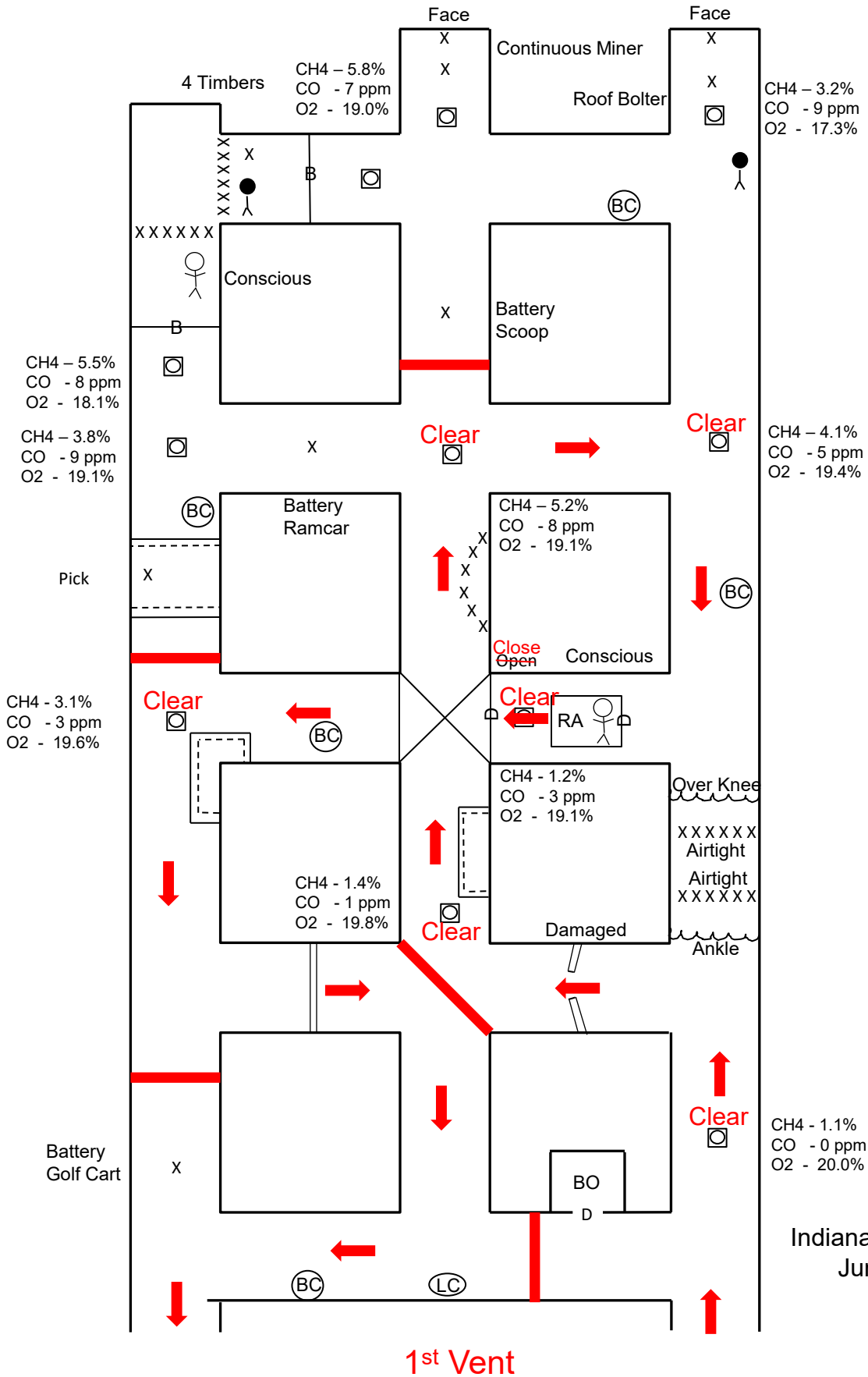

Indiana Mine Rescue
June 7, 2012

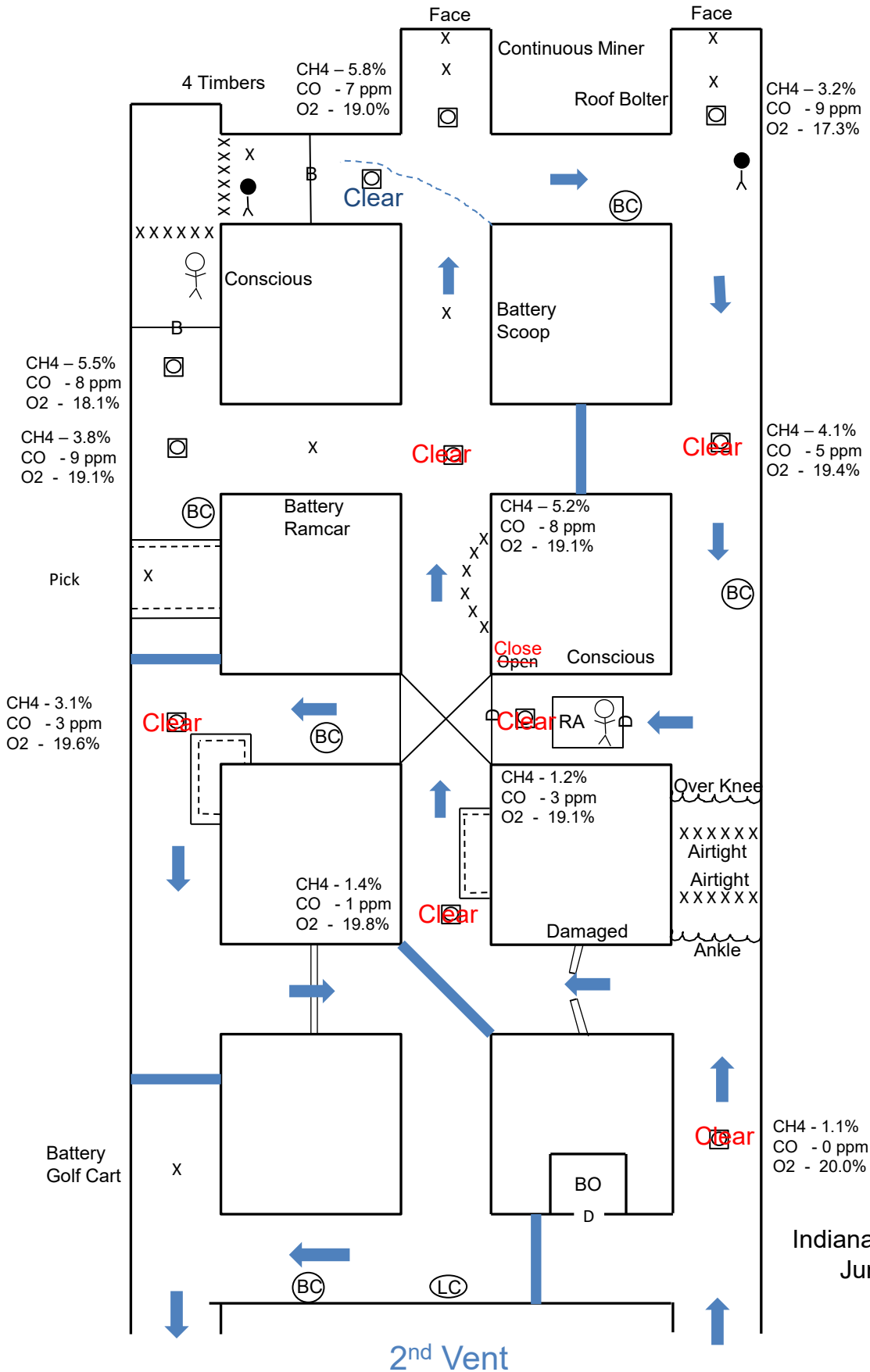

Indiana Mine Rescue
June 7, 2012

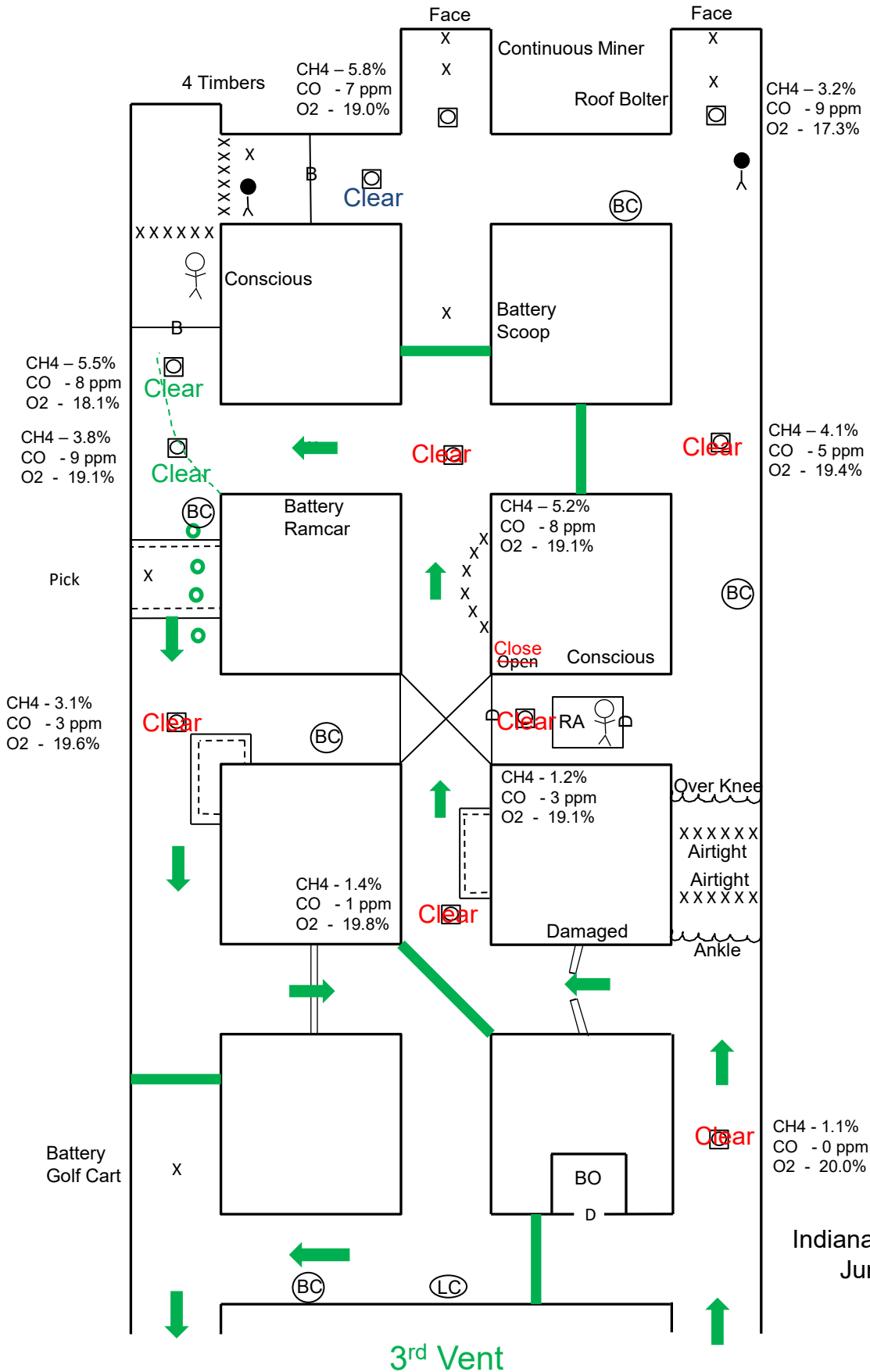

Indiana Mine Rescue
June 7, 2012