



38th

Alabama Coal Association



2014 Day 2 Problem Briefing



Beville State Community College

2014 ACA Contest Statement Day 2

Welcome to the Bear Run # 2 Mine. Bear Run has one miner section with three entries driving into virgin coal. Last night two mechanics and a scoop man went to the section to repair the continuous miner. Six hours into the shift, the scoop man on the section called the responsible person outside to report that he was knocked down by a burst of air and had hit his head on the mine floor. He said that he felt dizzy and that he was going to try to walk inby to check on his buddies. The responsible person tried to get the scoop man to stay on the phone, but further attempts to contact him failed.

We have explored the entries going into the highwall mine and found water in no.1 and no.2 entry. We also found dangerous amounts of methane coming from the no. 3 entry and decided to call a trained mine rescue team. You are located in the first crosscut just inside the mine. The mine is ventilated by an exhaust fan in the offset from no.1 entry. The fan is off at this time, but can be started by asking the superintendent.

Mine maps are not up to date. We have had problems with our contract engineers supplying us proper maps. We have back up teams here to assist you and all power inby the fresh air base is locked out and guarded. We do have an airshaft in the no.2 entry that was just completed and can be used if you think necessary. This is all we know at this time.

2014 ACA Day 2

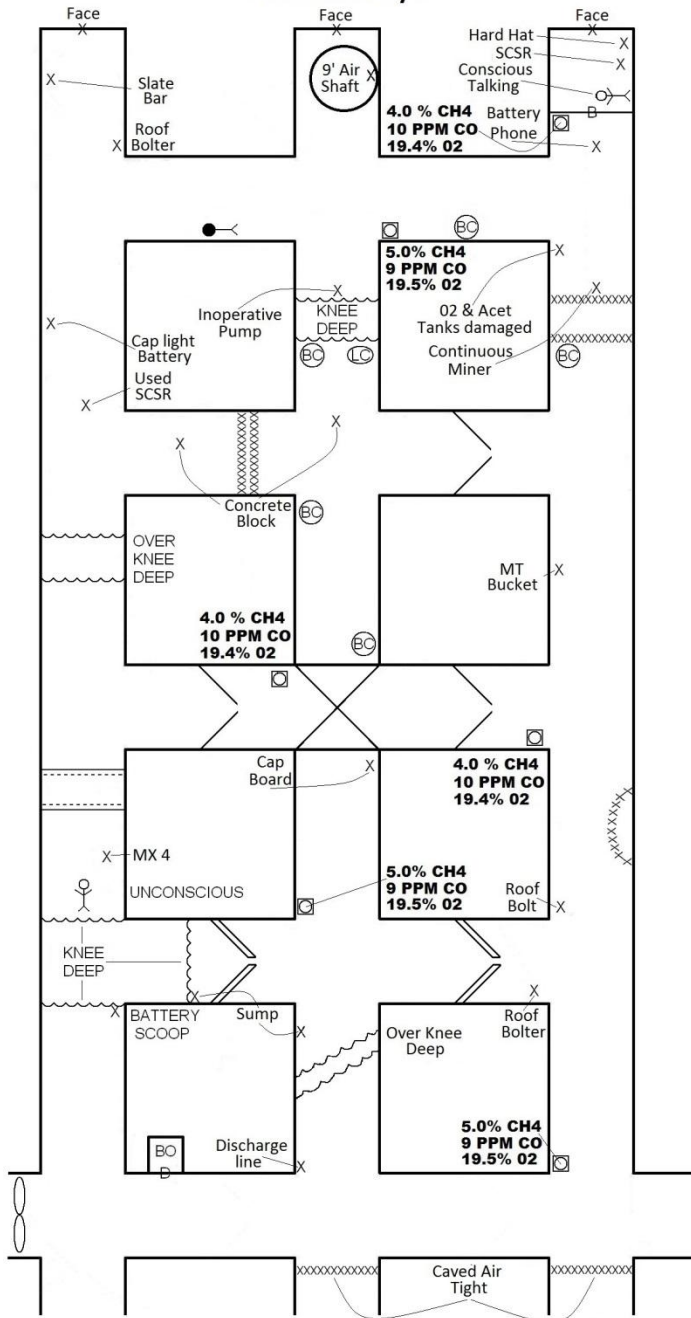

2014 ACA DAY 2

Problem

(Written Instructions)

- **ACCOUNT FOR THE MISSING MINERS**
- **BRING LIVE PERSONS TO FRESH AIR BASE**
- **REPORT ALL EXPLOSIVE MIXTURES IN WRITING TO THE SUPERINTENDENT BEFORE MOVING TO NEXT TEAM STOP**
- **THE EXHAUST FAN CANNOT BE REVERSED**
- **THE EXHAUST FAN CANNOT BE STOP OR STALLED AFTER STARTING**
- **TEAMS CAN CARRY ONLY 2 BRATTICE CLOTHS WHEN TRAVELING**
- **BO IS IN AN AIRTIGHT ENCLOSURE AND ISOLATED**
- **YOU HAVE 80 MINUTES TO WORK BEFORE BEING REPLACED BY ANOTHER TEAM**

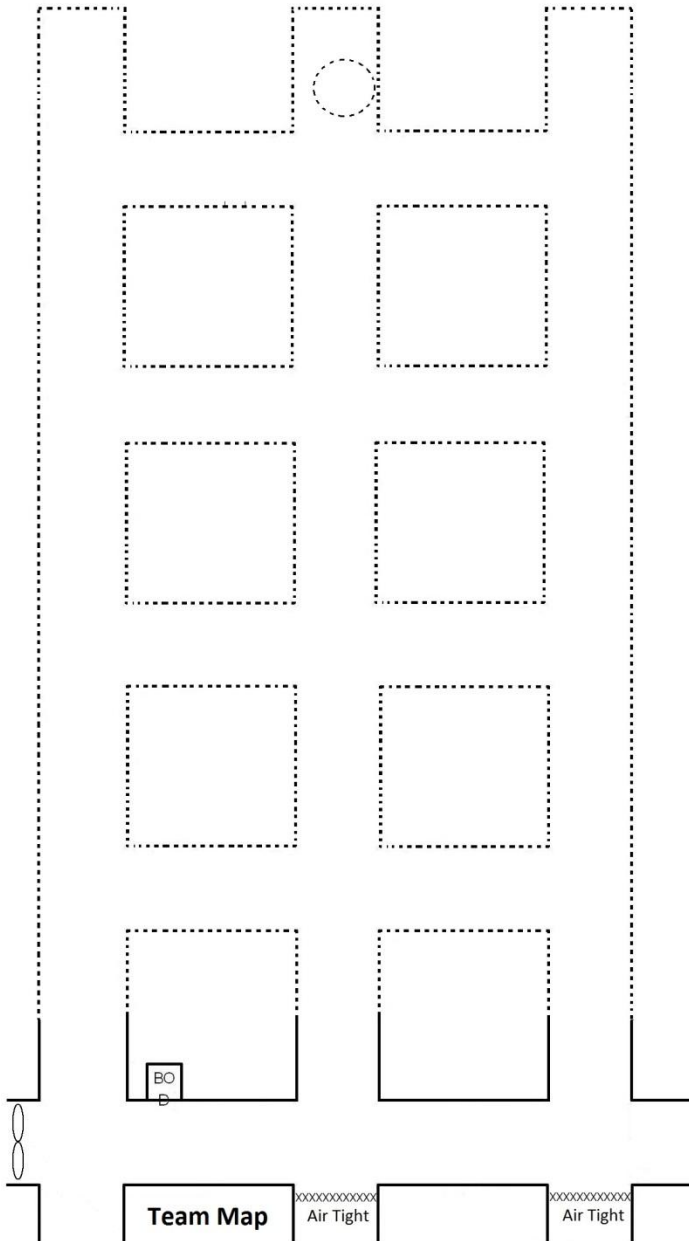

Team Map

xxxxxxxxxxxxxxxx
Air Tight

xxxxxxxxxxxxxxxx
Air Tight

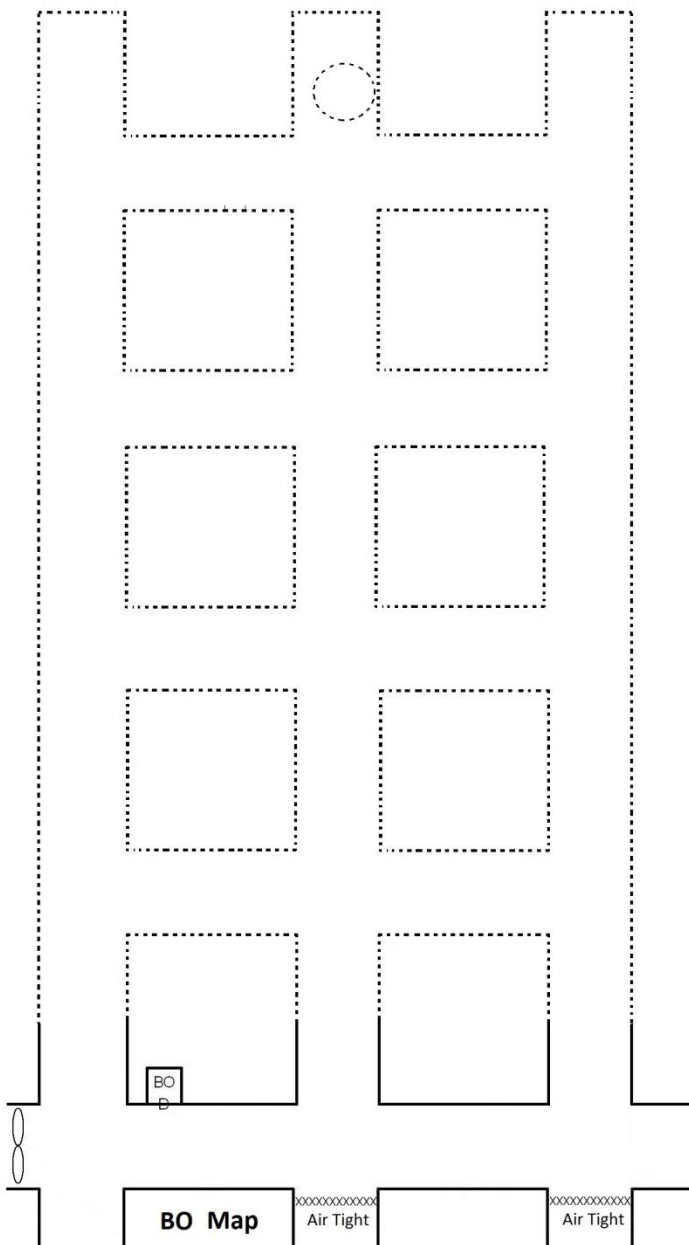

Possible Team Stops

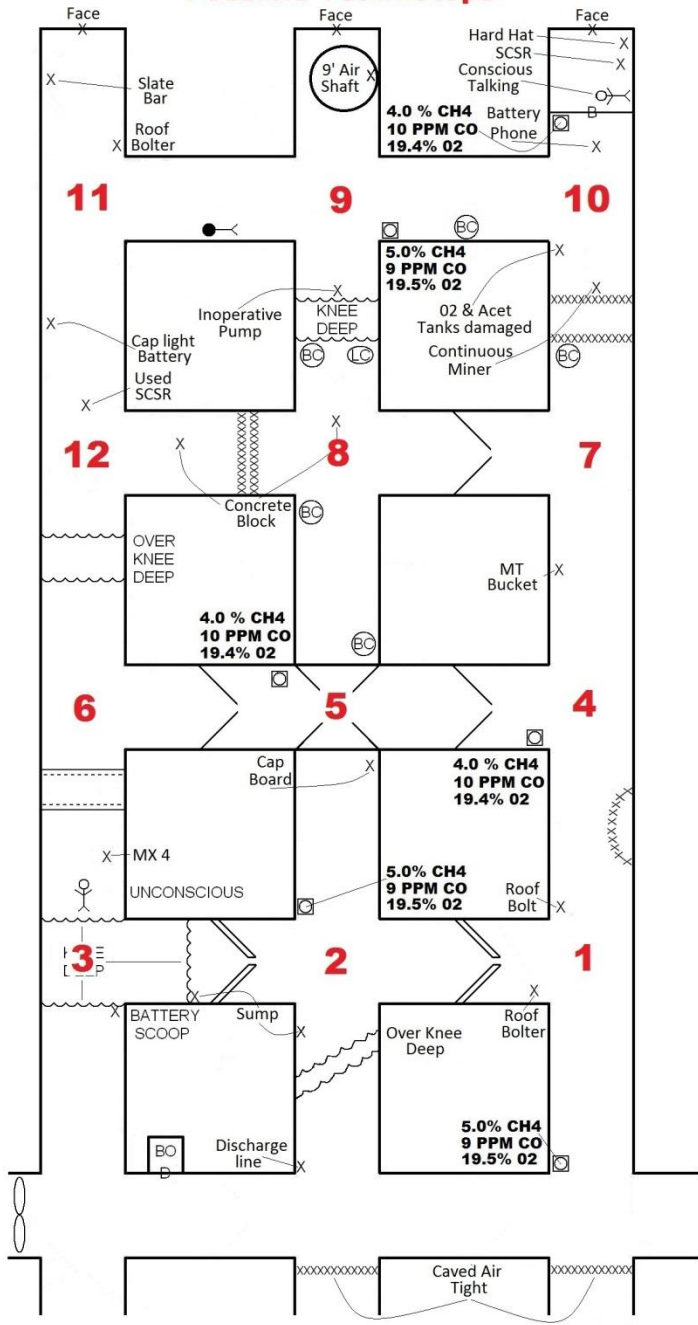

PATIENT STATEMENT
IN BARRICADE IN
NO.3 ENTRY INBY
LAST CROSSCUT

**HELP! IT'S AIRTIGHT
BEHIND ME!**

Gas Test

Date & Initial

Roof & Rib

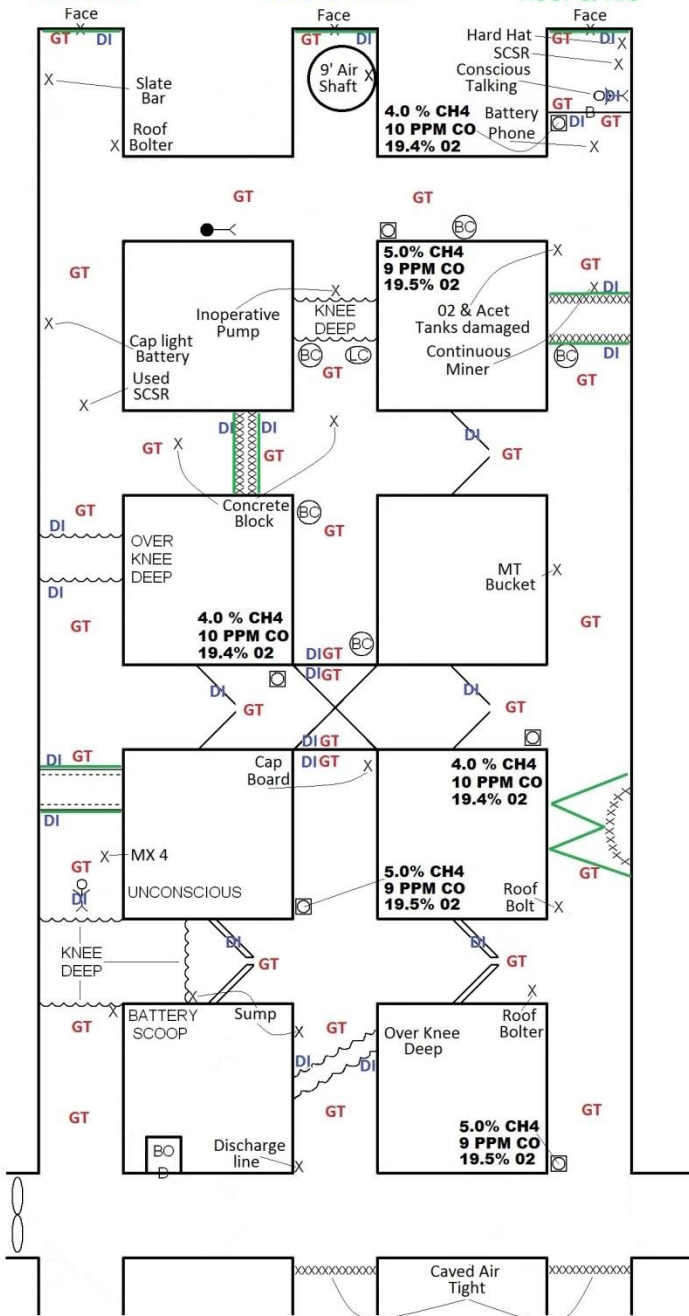

Explosive **Irrespirable** **Unexplored** **Ignition Source**

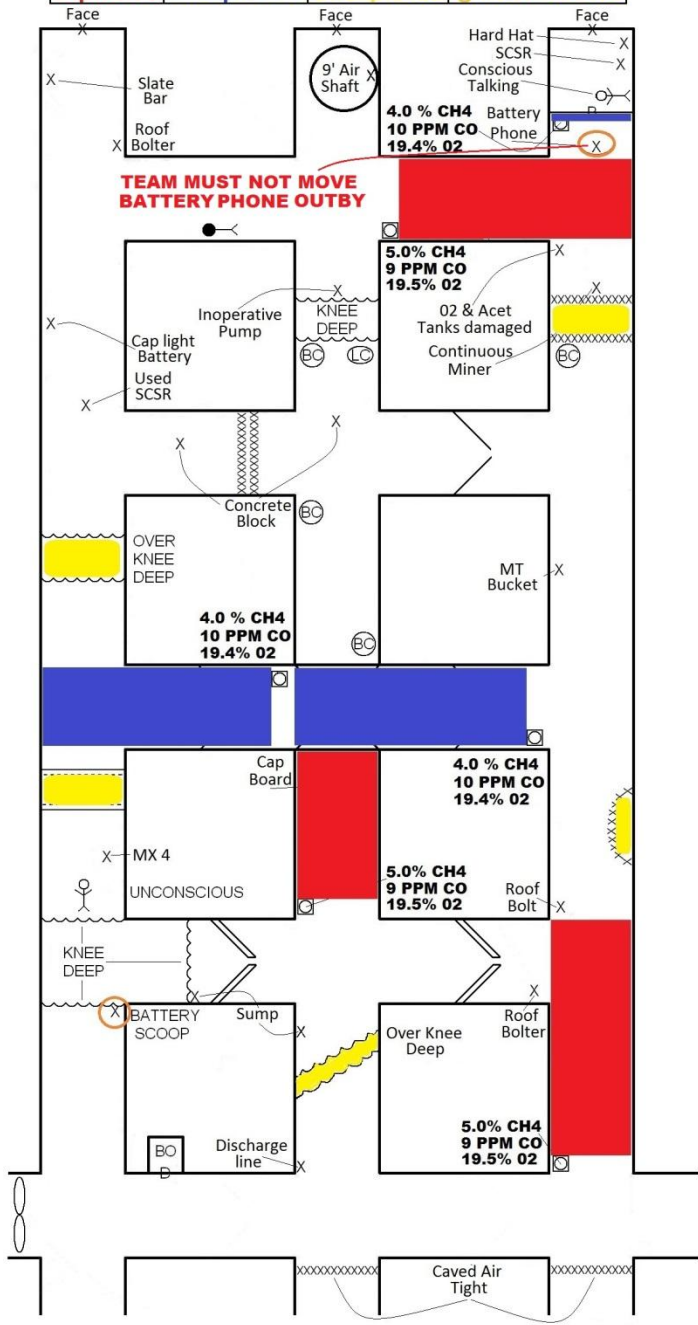

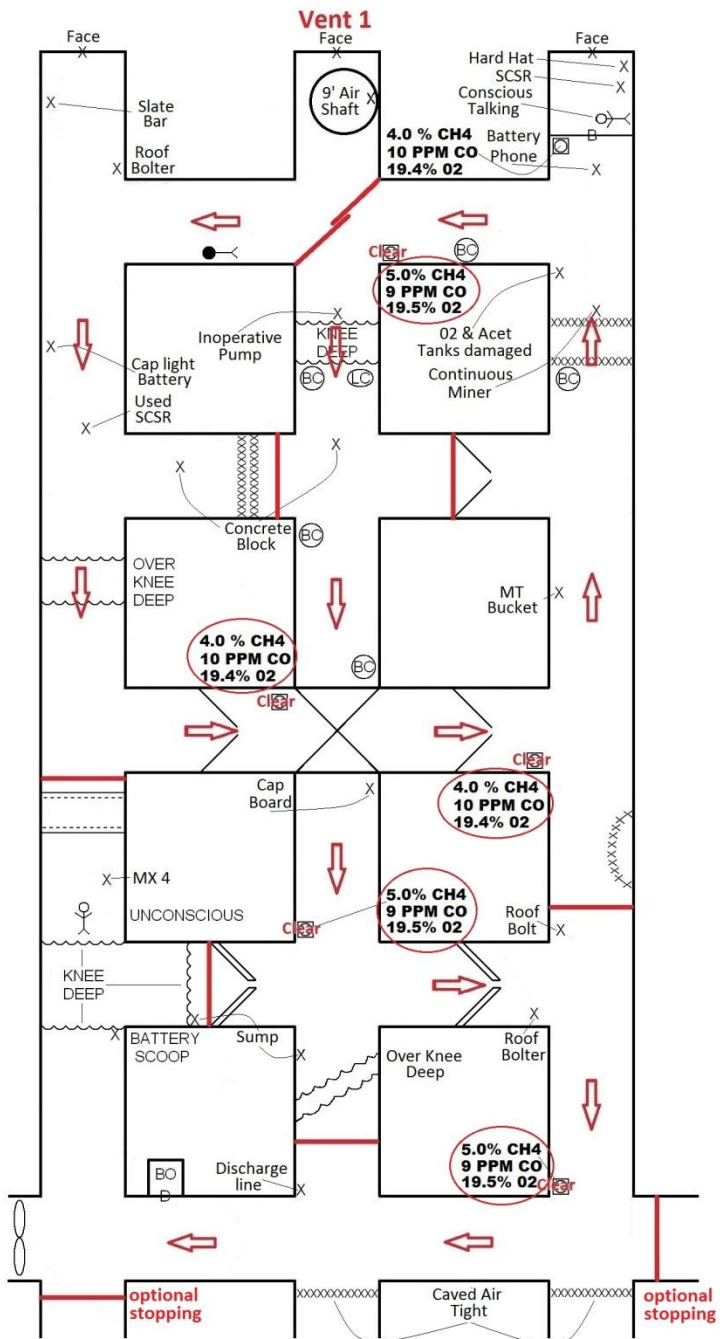

**VENT 2 IS HANGING
WING TO BARRICADE**

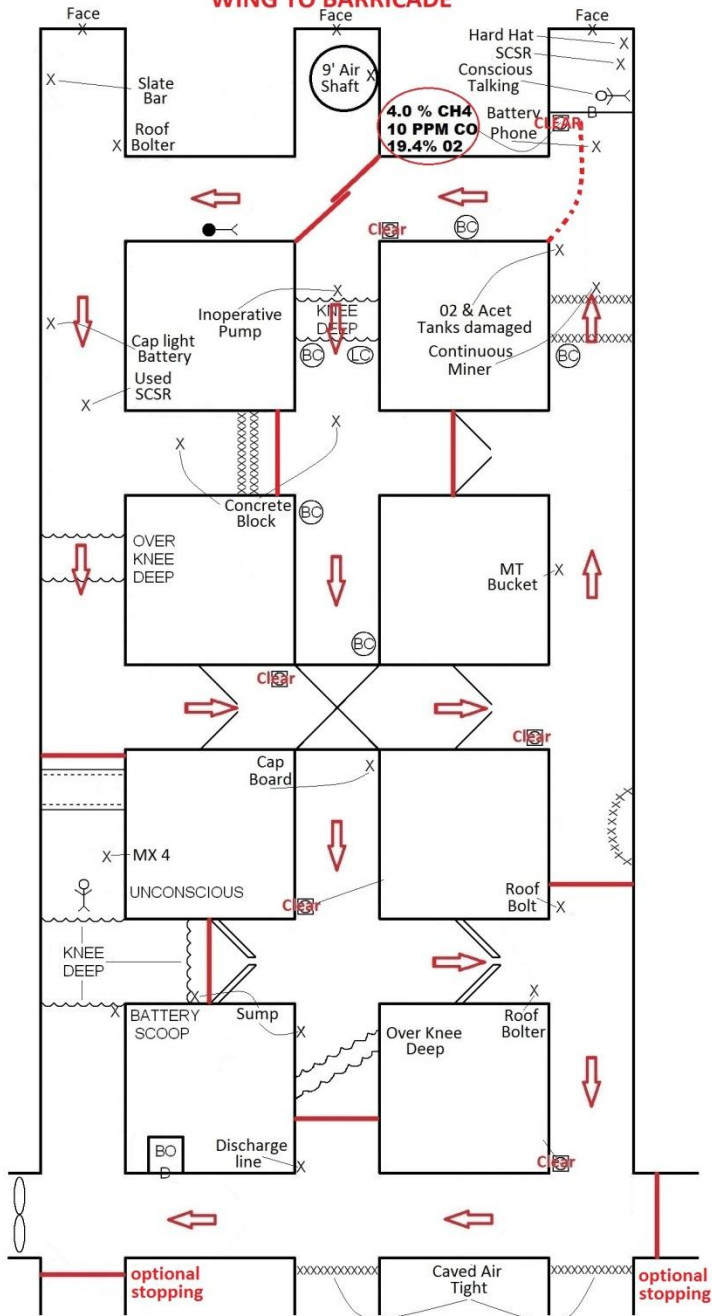

Keys to Problem

- **TEAM MUST TRAVEL UP NO.3 ENTRY TO BEGIN EXPLORATION**
- **TEAM CAN BRING UNCONSCIOUS LIVE PERSON OUT BAREFACED**
- **TEAM MUST EXPLORE TOWARD NO.3 ENTRY BEFORE GOING TO NO.1 ENTRY IN LAST OPEN CROSSCUT**
- **TEAM CANNOT VENT BARRICADE CORRECTLY UNTIL ALL OF THE MINE IS EXPLORED**
- **TEAM MUST NOT MOVE BATTERY PHONE OUTBY UNTIL EXPLOSIVE MIXTURE IS MOVED IN INTERSECTION**
- **ONLY ONE WAY TO MOVE EXPLOSIVE MIXTURE CORRECTLY IN INTERSECTION OUTBY BARRICADE (SEE VENT 1 MAP)**
- **TEAM MUST NOT TAKE EXPLOSIVE MIXTURE OVER ANGLED WATER OVER KNEE DEEP IN NO.2 ENTRY JUST INBY FRESH AIR BASE**
- **TEAM MAPS ARE DOTTED LINES JUST INBY FRESH AIR BASE**