

**Day 2
Team Instructions
Problem**

- Account for all missing miners. ✓ 5
- Explore all parts of the mine that can be safely explored ✓ 5
- The mine fan cannot be stopped, stalled, or reversed.
- At each apparatus check, the name of the team member with the lowest oxygen level and the oxygen level must be call out to the command center (briefing officer if there is no command center attendant) prior to the team moving from that team stop. -5
- The team cannot move any barricade nailed to the ground.
- The team must comply with all team notes provided to them.
- A time limit of ~~90~~¹⁰⁵ minutes has been established for this problem. The team will be advised 10 minutes prior to this time limit expiring.

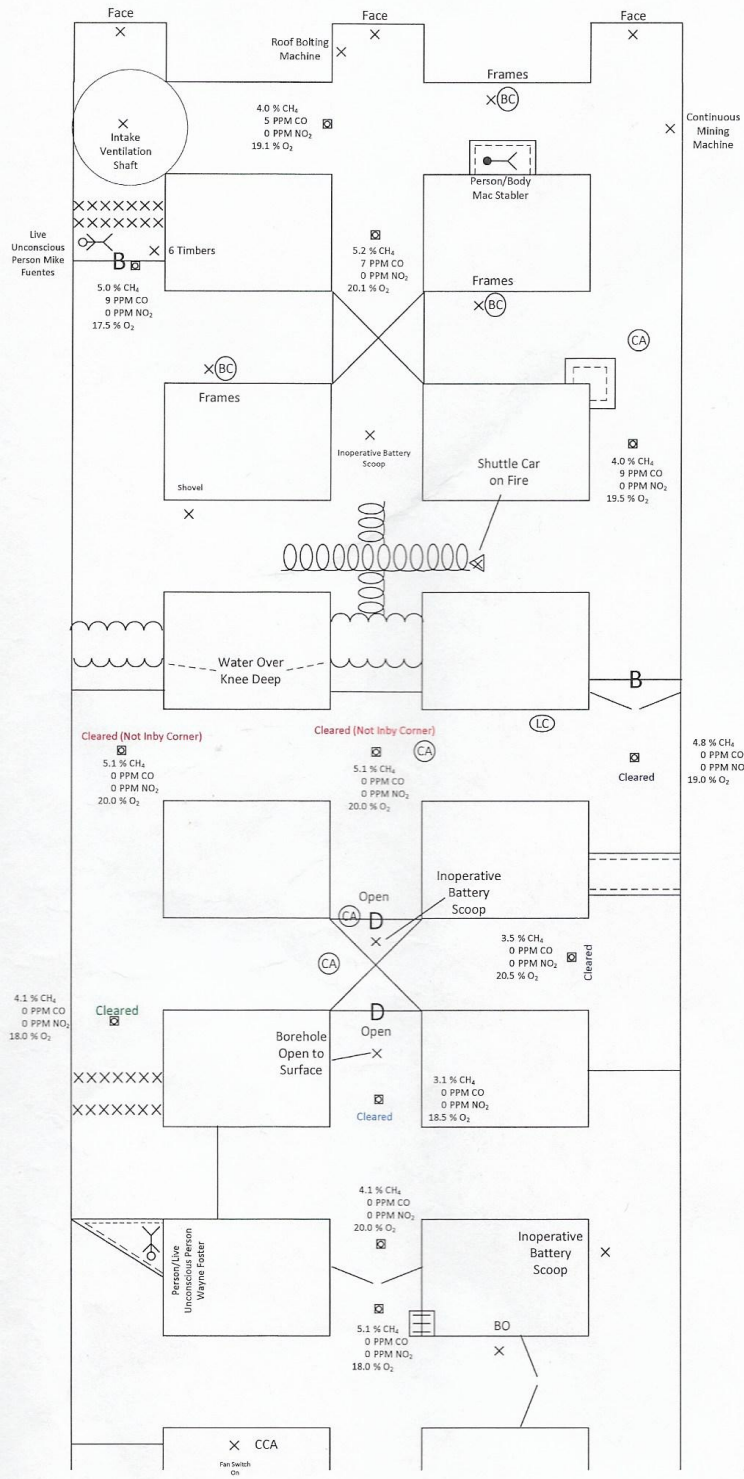

DAY 2

Virginia Mining Institute
V-2-21

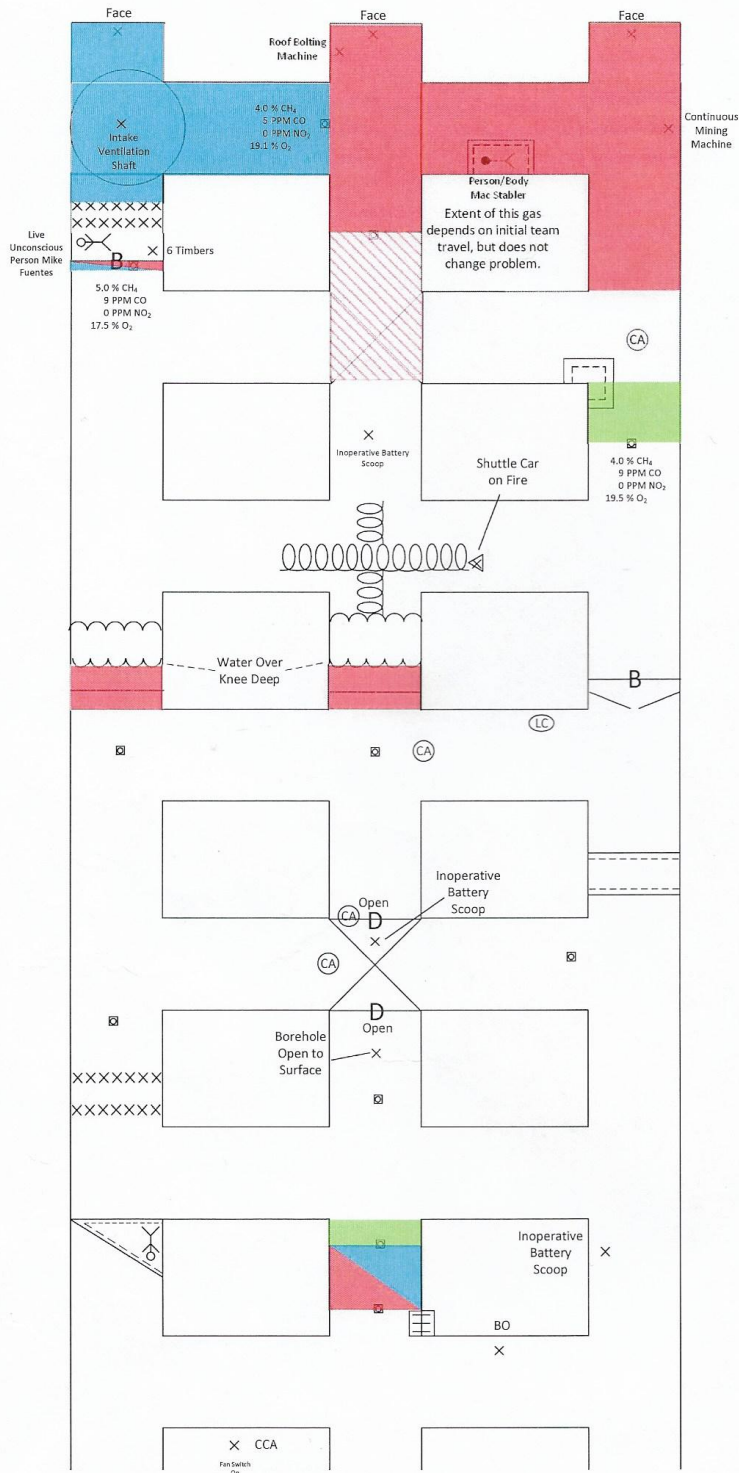

Virginia Mining Institute
 V-2-21
 Extent of Gasses

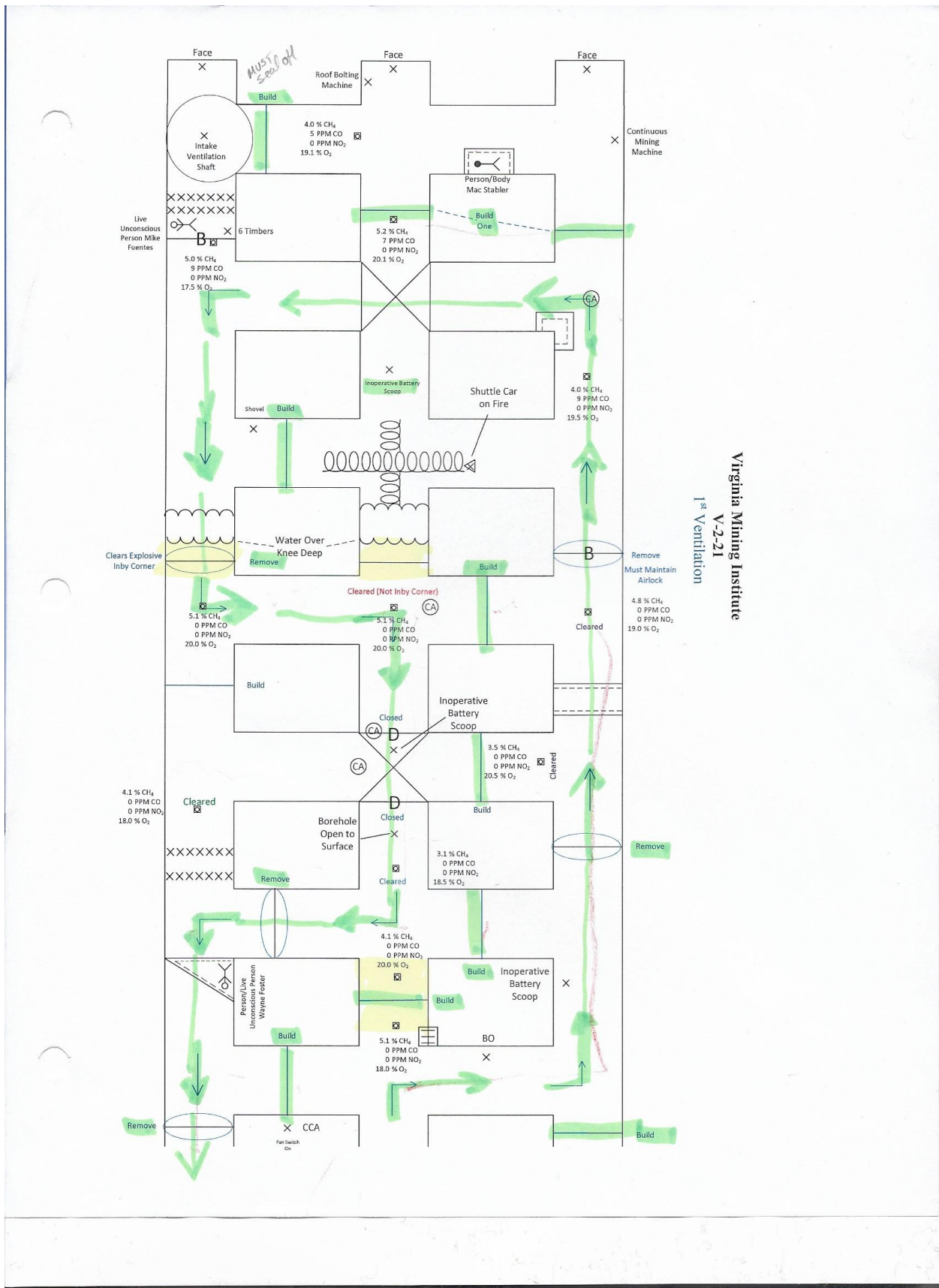

Virginia Mining Institute
 V-2-21
 1st Ventilation

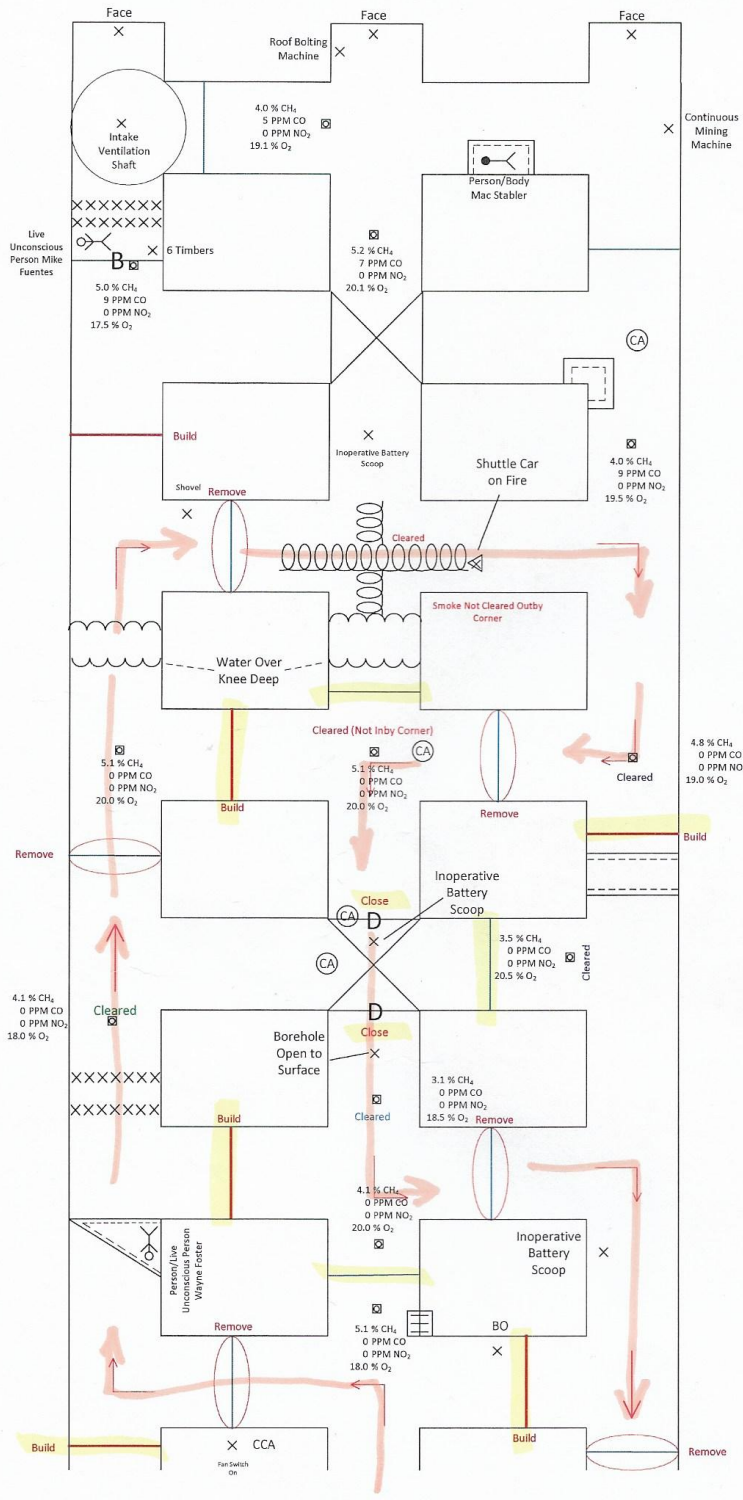

Virginia Mining Institute
 V-2-21
 2nd Ventilation

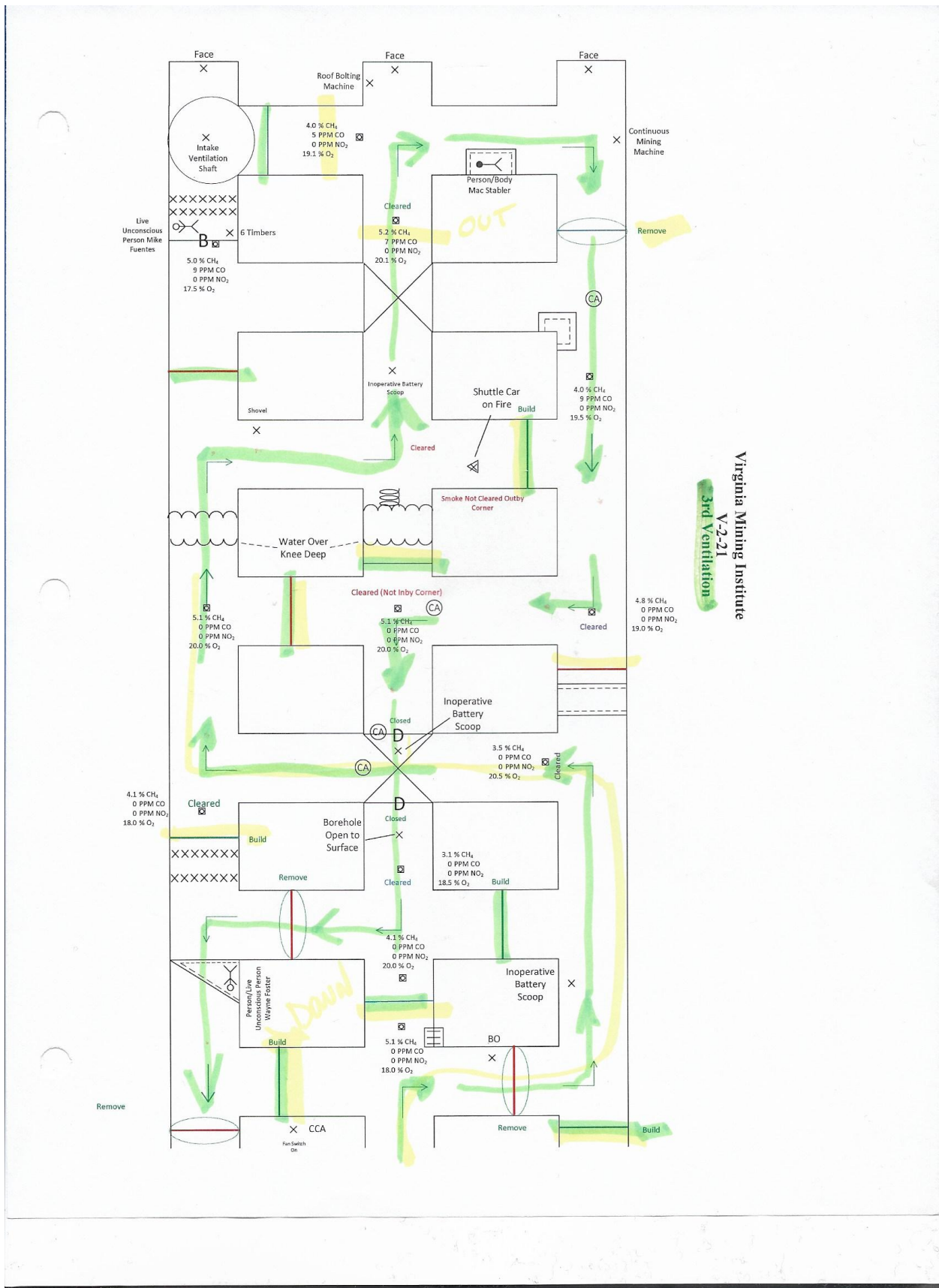

Virginia Mining Institute
V-2-21
3rd Ventilation

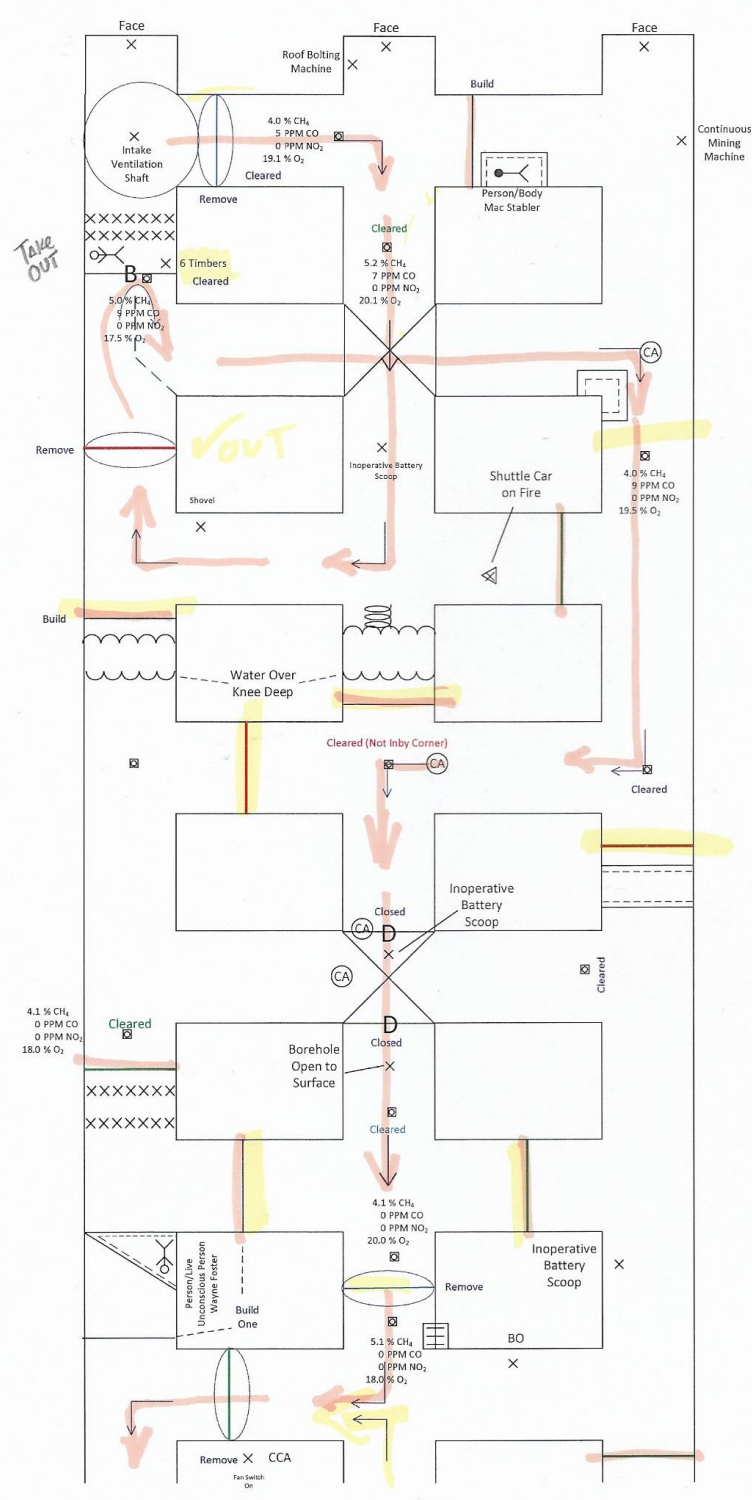

Virginia Mining Institute
 V-2-21
 4th Ventilation

Virginia Mining Institute
V-2-21
Team Stops

