

# STATEMENT

Hello, my name is Bo Bender. I am the mine foreman at this mine. A four-man maintenance crew entered the mine at 4:00 am last night. The outside communications man stated that after the call from the foreman that they had arrived on the section at 4:10 am, he has not been able to contact the crew. There has been some type of problem underground and we need your rescue team's help. There are four miners missing in the mine. The fan is a blowing fan located at the portal of the No. 3 entry. The return entry is normally the No. 1 entry. The fan is running and can not be stopped stalled or reversed. The prior mine rescue team has established a fresh air base underground and fresh air has been directed to that point. All power going underground has been locked out and is presently being guarded.

There are several mine rescue teams on site and are available to serve as your back-up team when your team is underground to explore for the missing miners. All authorities have been notified and local law enforcement is on their way to provide security to the mine. This is all the information that is available at this time. A map and written instructions will be provided to you when the clock is started.

# WRITTEN STATEMENT

Explore the mine

Rescue all survivors

Bring survivors to the surface of the mine



# CONTEST PROBLEM

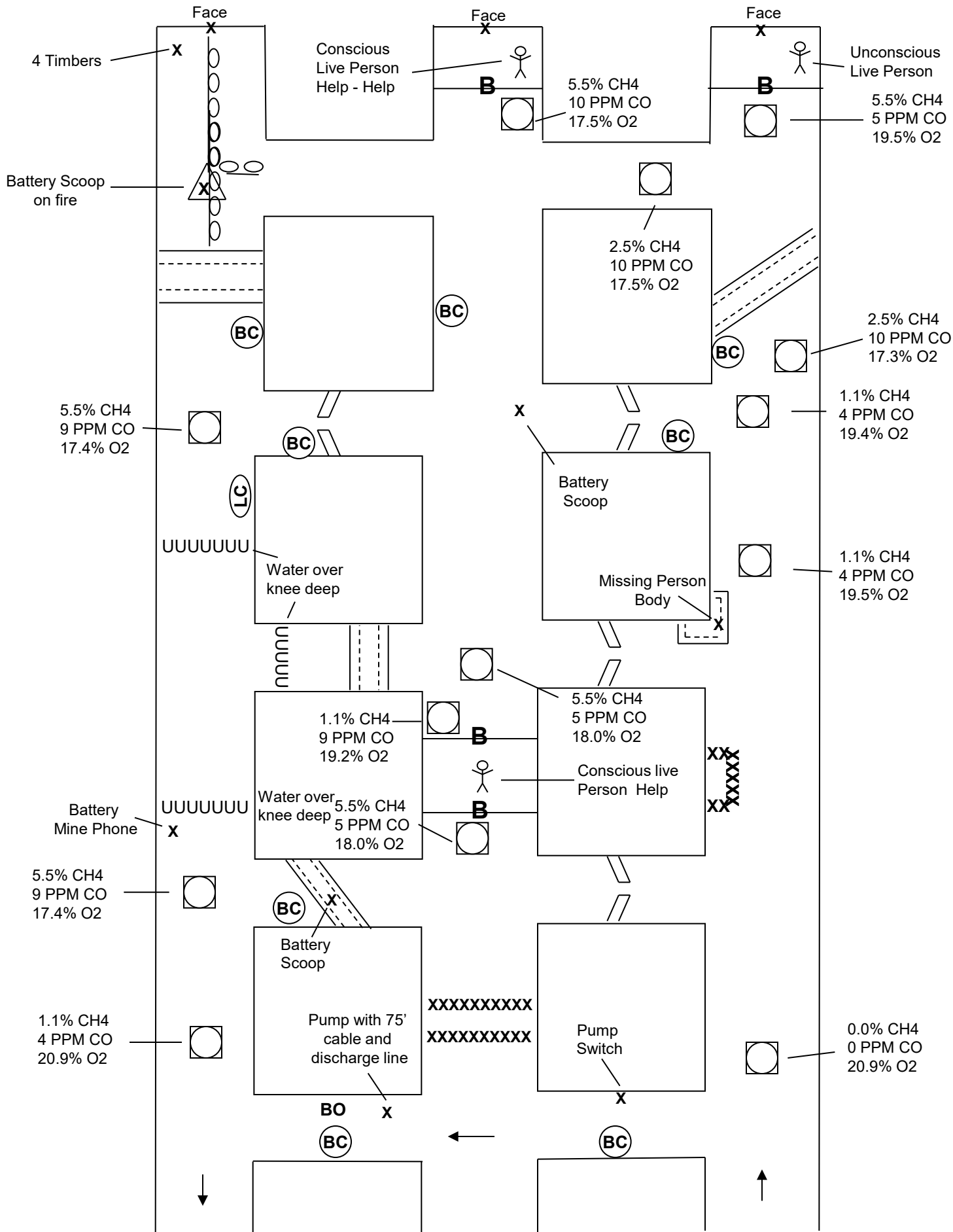

# PROCEDURE

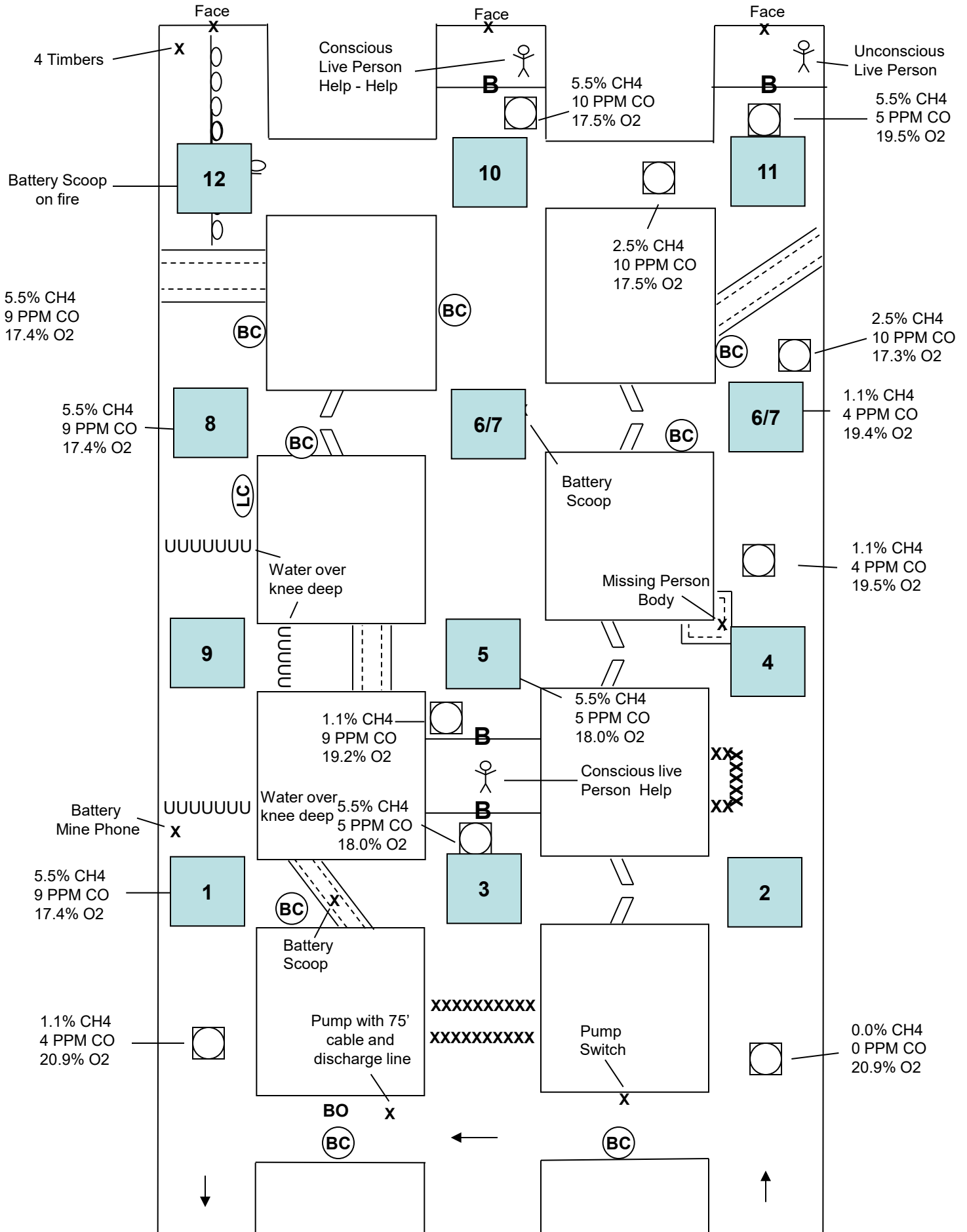



# SECOND VENTILATION

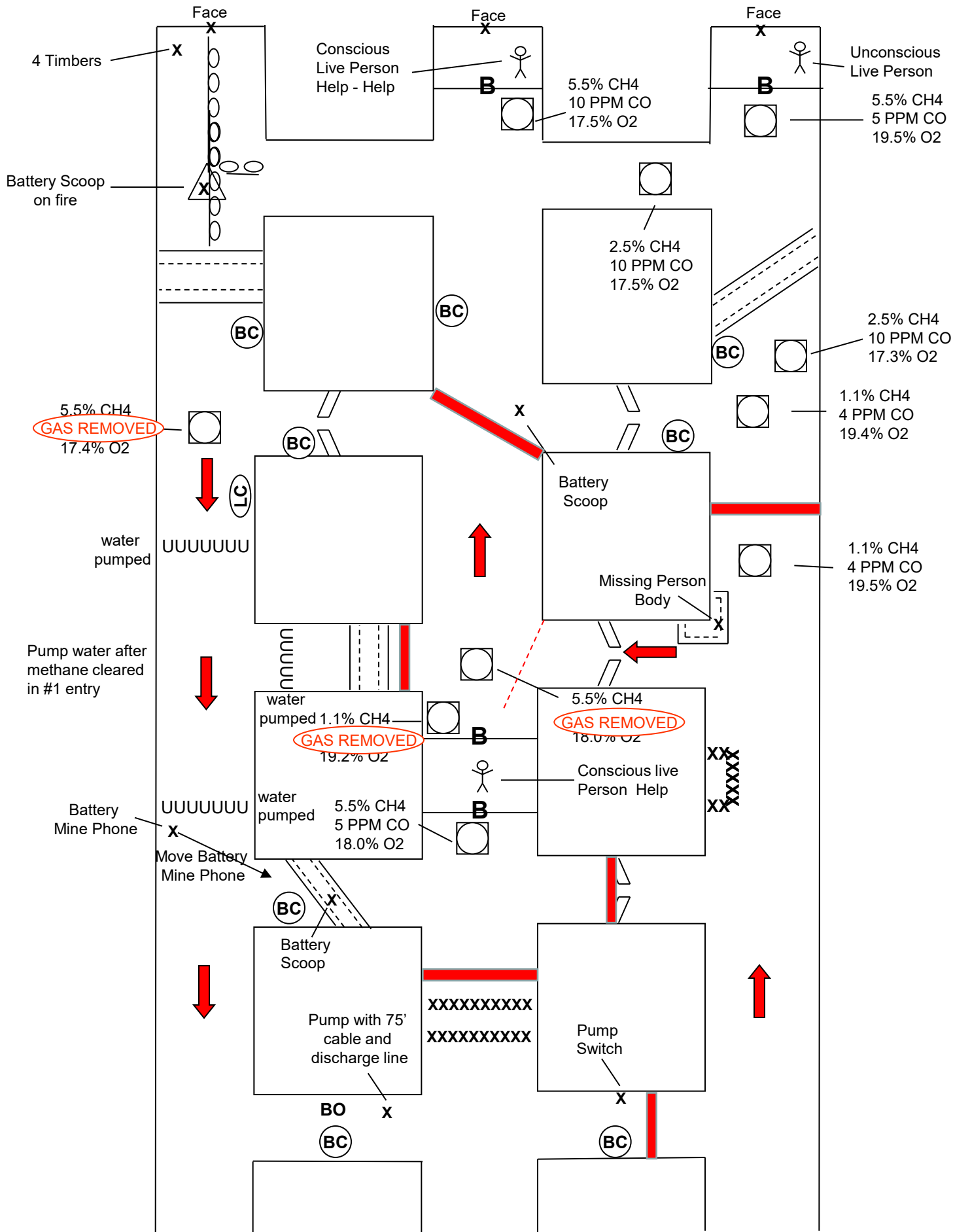

# THIRD VENTILATION

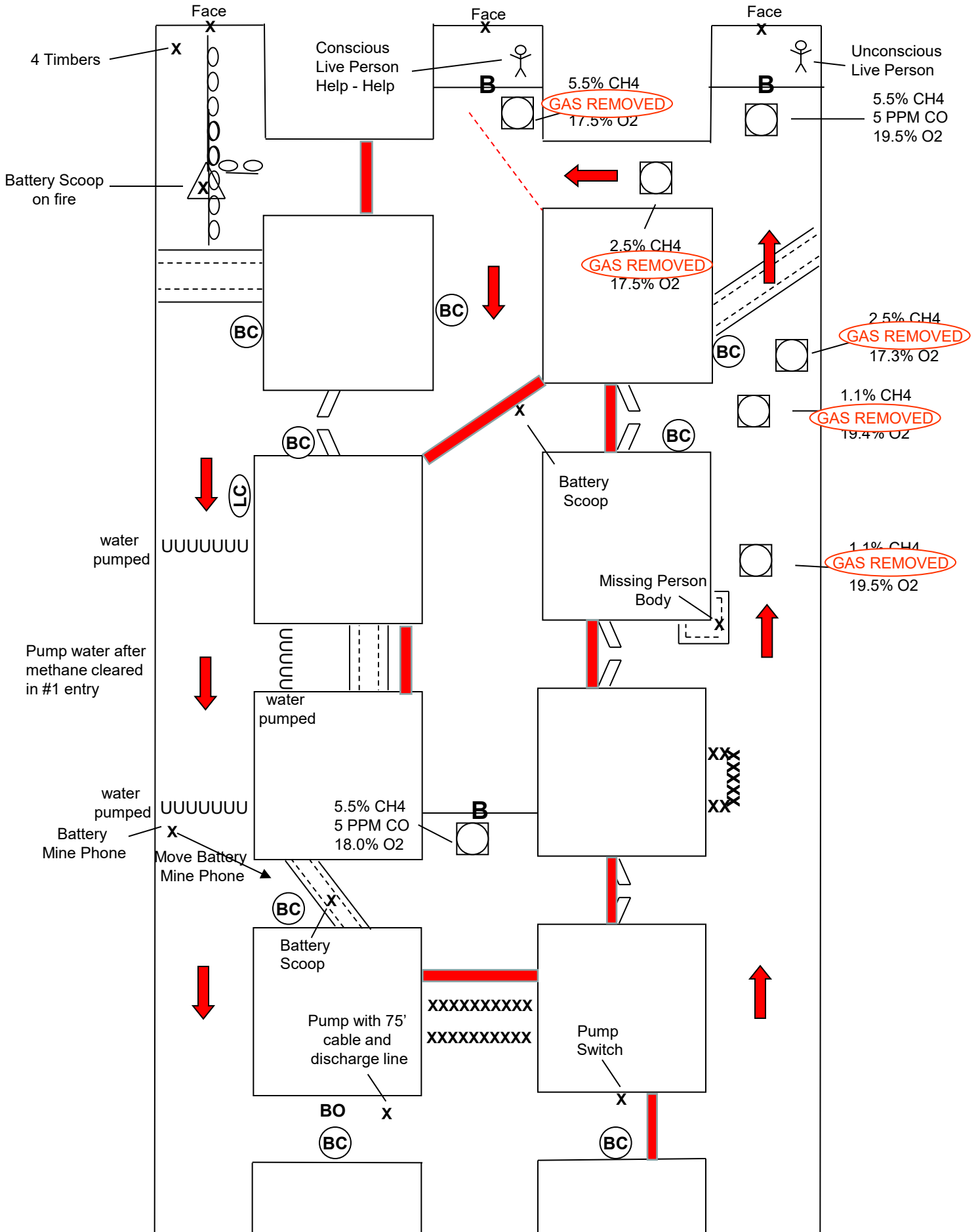

# LAST STEP - TIMBERNG

