

# DAY 1 – COMPETITION STATEMENT

Hello my name is \_\_\_\_\_. I am the mine foreman here at the mine. Last night on the midnight shift we had ten employees go underground to build stoppings, clean and rock dust, wash equipment and do routine maintenance work on our equipment. Our fire boss arrived at the mine at approximately 5:00 am and attempted to contact the crew before starting his examination of the mine. He was unable to make contact with anyone underground. He traveled to the section to determine what kind of problem existed. When he got four breaks from the face area he encountered unsafe roof in No. 1 entry, unsafe roof in No. 2 entry and an explosive range of methane and low O<sub>2</sub> in No. 3 entry. None of these conditions were in the pre-shift examination book prior to the midnight crew going to the section. Permanent stoppings were built across all three entries and a Fresh Air Base was established. He then returned to the surface of the mine to get help and notify designated persons in the mine emergency plan. I arrived at the mine site at 7:00 am and notified all agencies and contacted our mine site rescue team and two contract teams in the area. Your team is the first to arrive at the mine site.

The area of the mine where the missing miners are located is an three entry section and the entries are numbered from left to right with No. 1 entry being on the left side of the section looking inby to the face areas. This area of the mine is ventilated with two fans. Each source for the fans will be capable of providing 20,000 cfm. The No. 1 fan is located in an entry driven off No. 1 entry. It is a blowing fan that is presently off but can be started by the briefing officer contacting the mine foreman. Once the No. 1 fan is started it can not be stopped, reversed or stalled. The No. 2 fan is located on the surface of the mine in No. 3 entry. It is a exhausting fan that is presently running and can not be stopped, stalled or reversed. The No. 2 fan can not pull over 80,000 cfm at any time.

Recently a crack in the mine floor appeared in No. 2 entry where the fresh-air base is located and large amount of methane was detected at this location. It has been determined that a minimum of 40,000 cfm must be directed over the crack in the mine floor in order to maintain the methane level under the explosive range of methane. As the team explores this area of the mine, it will be mandatory to maintain 40,000 cfm over this area at all times. Both air shafts are equipped with air lock doors. The team may request that one of back up teams present at the mine close the air lock doors at the shafts by the briefing officer requesting the change thru the mine foreman.

You will be provided a mine map and a written statement when you have started the clock.

Good Luck

# WRITTEN STATEMENT

Explore the mine

Account for all missing miners

Rescue all survivors

Bring survivors to the fresh-air base of the mine

Once the Number 1 fan is started it can not be stopped, stalled or reversed

Number 2 fan can not be stopped, reversed or stalled

The team will be limited to carrying two brattice clothes when the team is traveling

# DAY ONE - COMPETITION

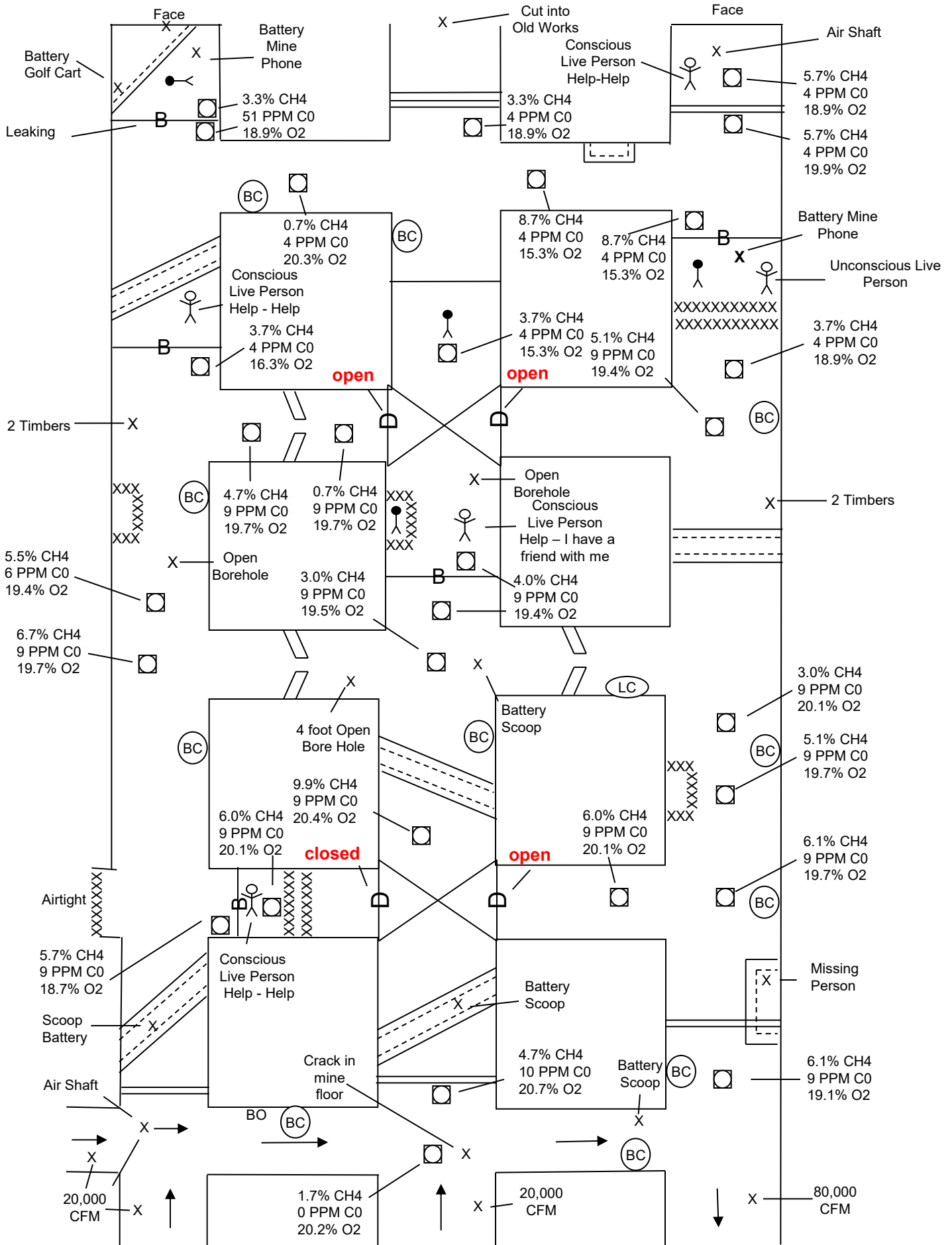



# DAY ONE – FIRST VENTILATION

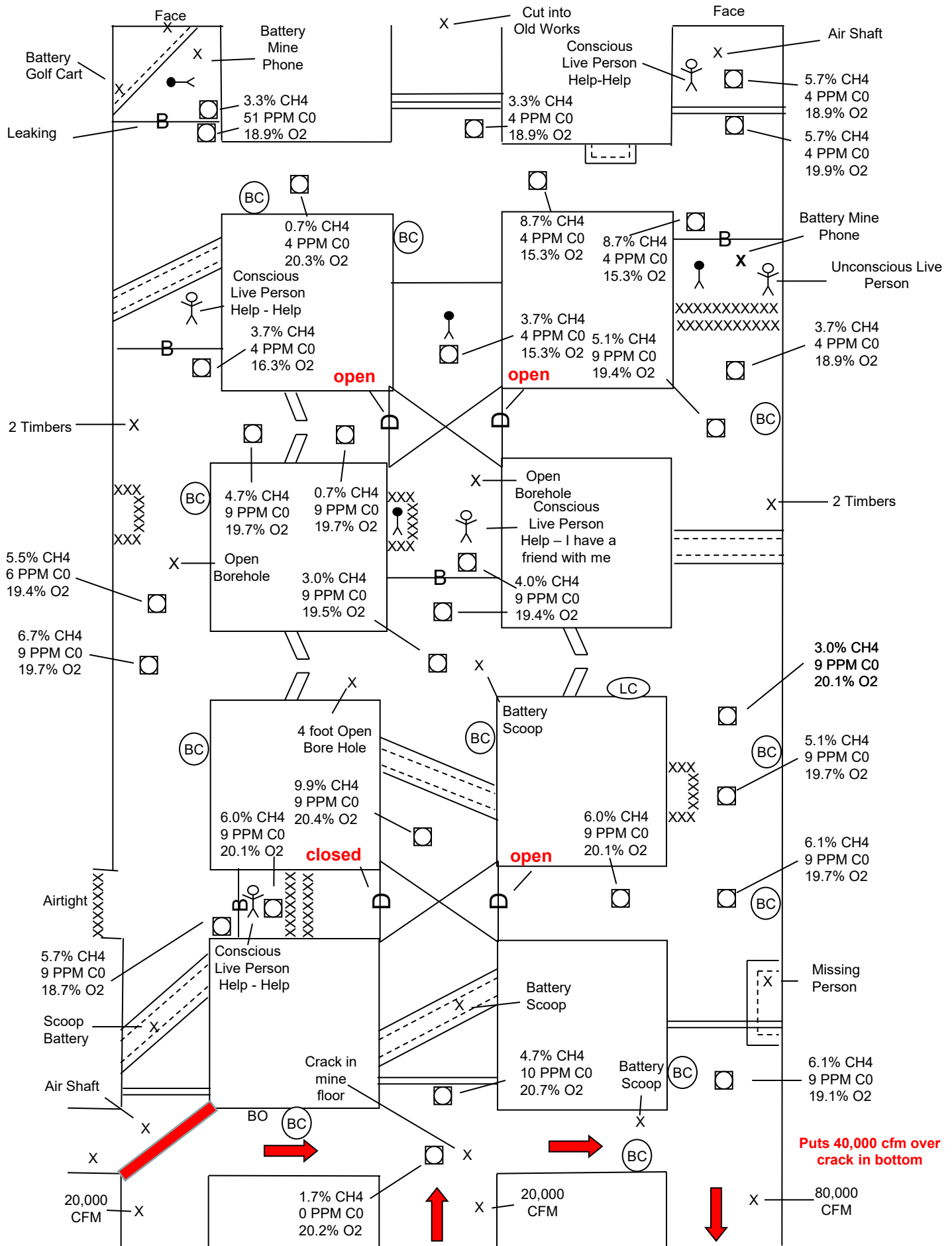

# DAY ONE - SECOND VENTILATION

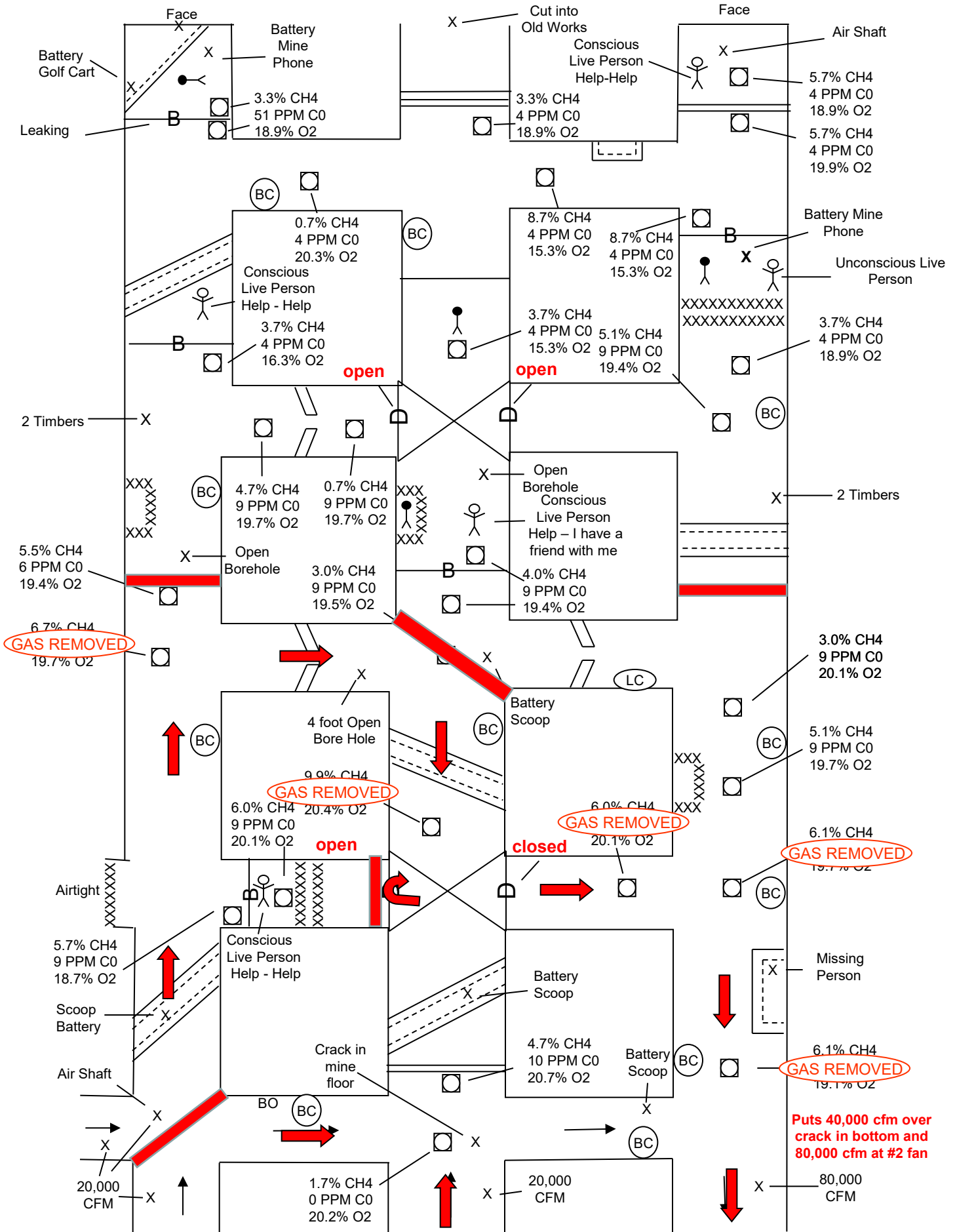







# DAY ONE – SIXTH VENTILATION

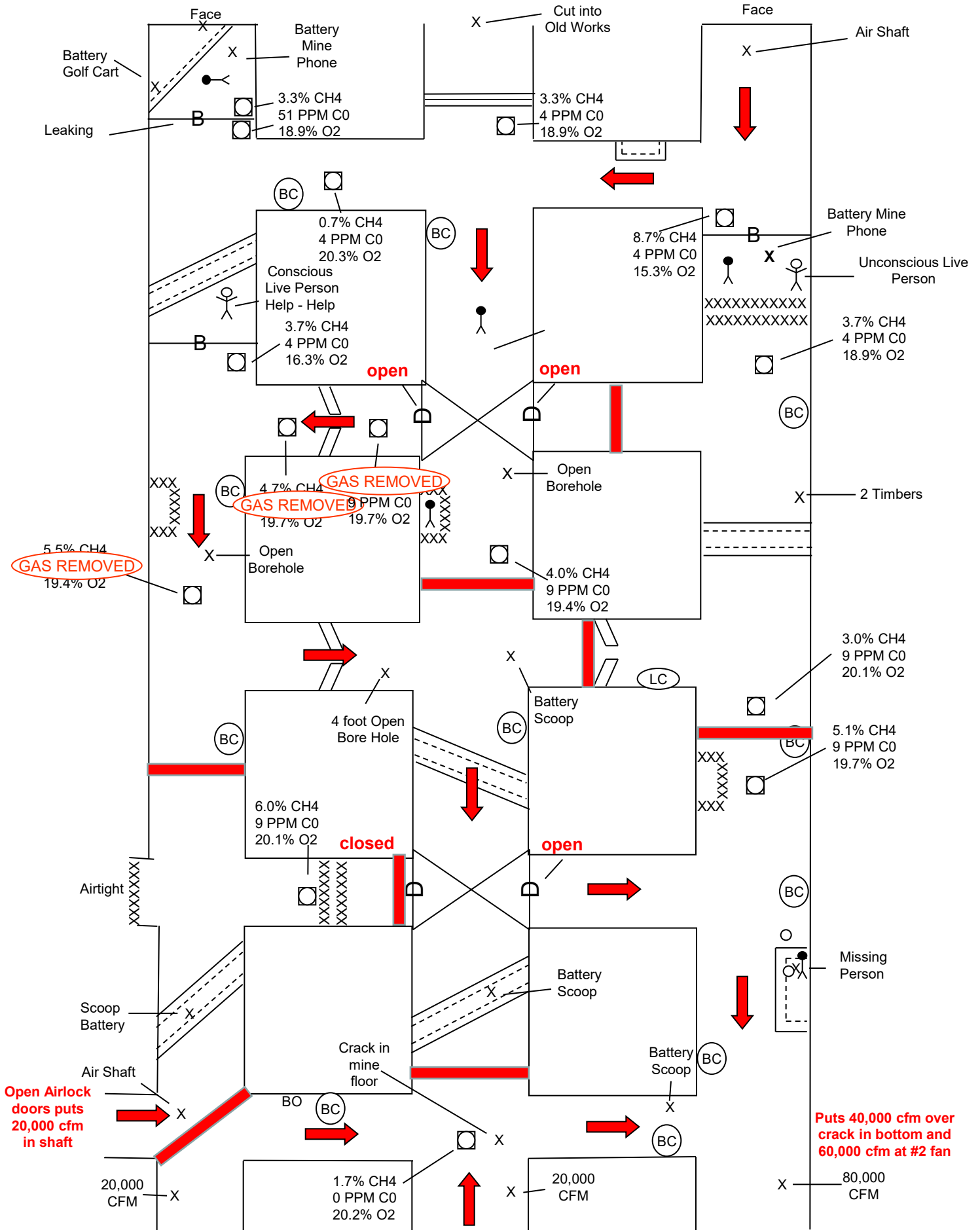



# DAY ONE – SEVEN “B” VENTILATION

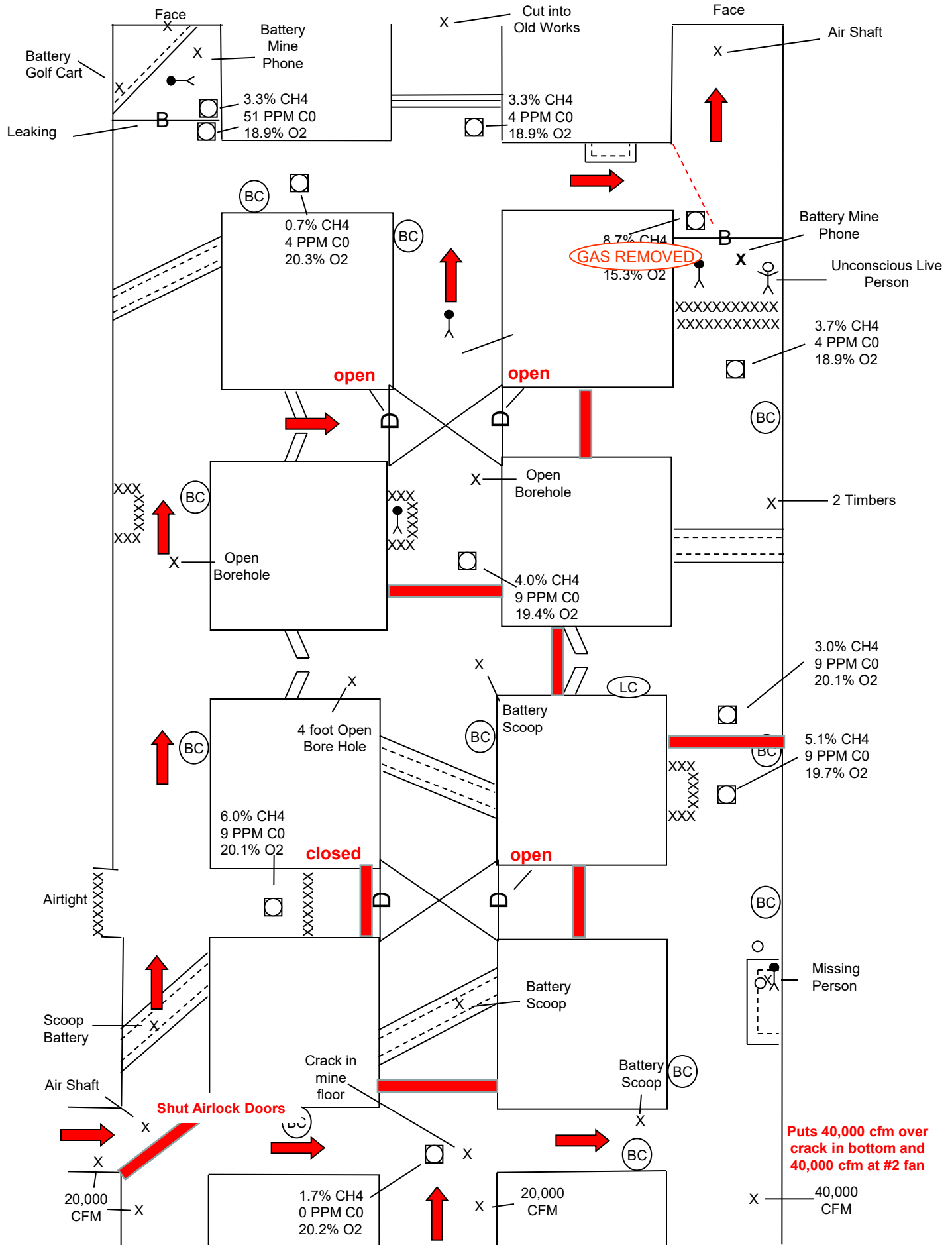

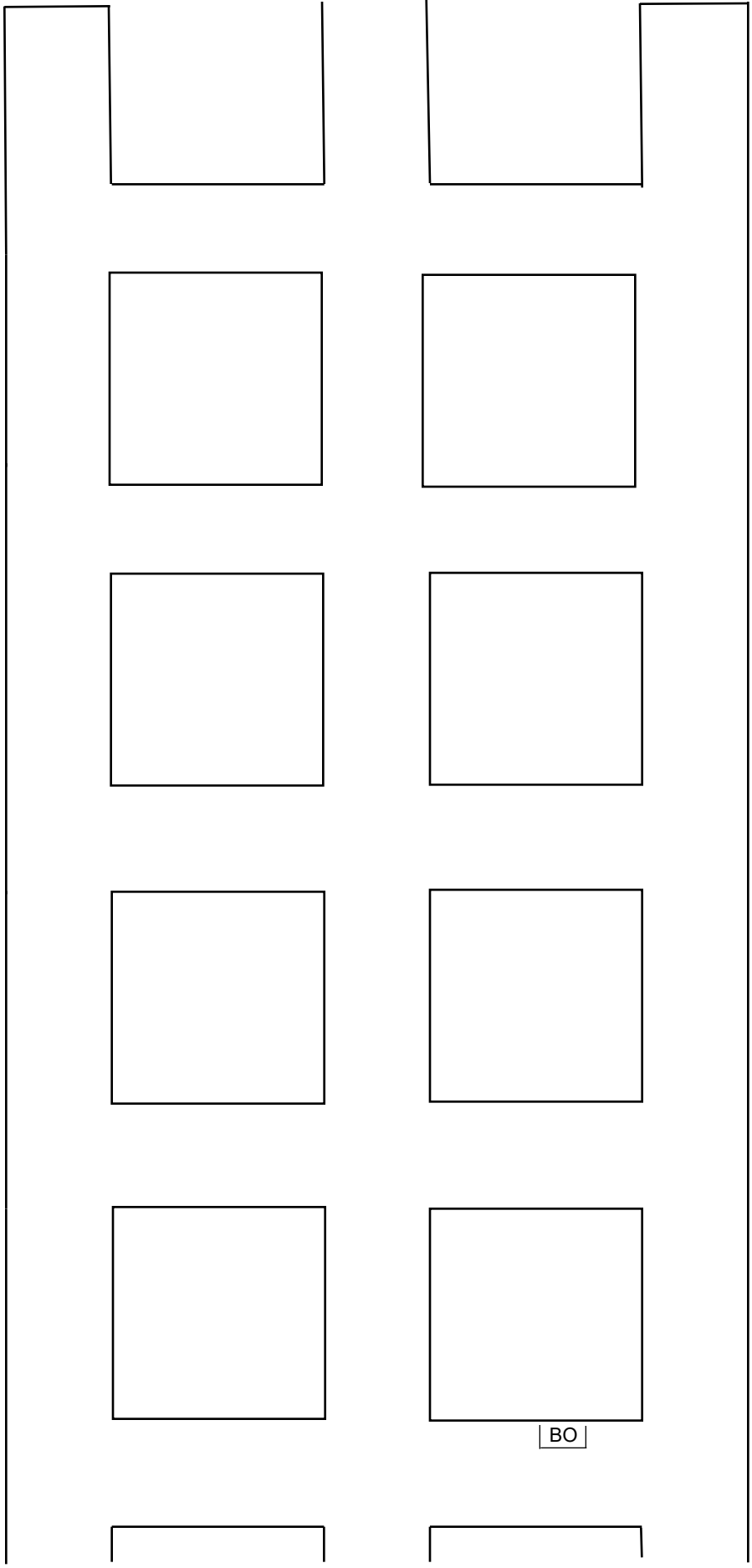

FINAL VENTILATION MAP

Mine Foreman

---

Team Captain

---

Team Number

---

BO